



NELMOR-GRANULATE

MEDIUM TANGENTIAL SERIES 2024 AND 2036



STANDARD FEATURES

- 24" and 36" wide models
- Angled infeed for easy hand or conveyor feed
- Convenient lower feed height of 63"
- Fully sound-dampened to 85dBa or less for most applications
- Tangential feed design for improved application versatility
- Machine bolted/doweled assembly for ease of cleaning and replacement
- Dual bed knives - counter slant, reversible and adjustable, doubling knife life
- 3 knife slant cut rotor (steep angle) including solid knife carriers
- Open design - scooped rotor for maximum air flow and ingestion of product
- Large 20" cutting circle on rotor for efficient processing of large bulky products
- High carbon, high chrome (D2) rotor and bed knives
- Swing down reversible screens with solid edges doubling screen life and providing easy maintenance
- Airveyor discharge standard
- TEFC design - 1800 RPM motor with sliding motor base
- NEMA 12 controls with safety switch meeting latest OSHA/ANSI specifications
- Disconnect switch 115V to push-button provides safer design

G SERIES TANGENTIAL GRANULATORS

AEC's 2024/2036 tangential granulators accept larger products with improved performance and are 100% American made. It offers customers a solution to granulation problems by minimizing part bouncing and optimizing material processing for large bulky parts.



1100 E Woodfield Road
Schaumburg, IL 60173 USA
Tel. 847-273-7700 Fax 847-273-7804

www..com



**WHITLOCK/
MATERIAL
HANDLING**



HEAT & COOL



**BLEND &
RECLAIM**



**NELMOR/
GRANULATE**



**DOWNSTREAM
EXTRUSION**



AUTOMATE



**SYSTEMS
CONTRACTING**



SERVICE



NELMOR-GRANULATE

MEDIUM TANGENTIAL SERIES 2024 AND 2036



Heavy-duty, easy access base creating a stronger design with easy cleanout and servicing.



High carbon, high chrome D2 knives for maximum knife quality and consistency. Solid knife carriers provide extra support.



Dual solid flywheels offer standard heavy duty cutting inertia.

OPTIONS

- Conveyor with amperage feedback system
- Pneumatic discharge systems
- Dust and angel hair removal system
- Specially designed feed hoppers

Model	A	B	C
2024	24"	52 5/8"	6"
2036	36"	62 5/8"	8"

Motor	Throughput
30 HP, TEFC, 1800 rpm	1400 lbs./hr (630 kg)
40 HP, TEFC, 1800 rpm	2000 lbs./hr (907 kg)

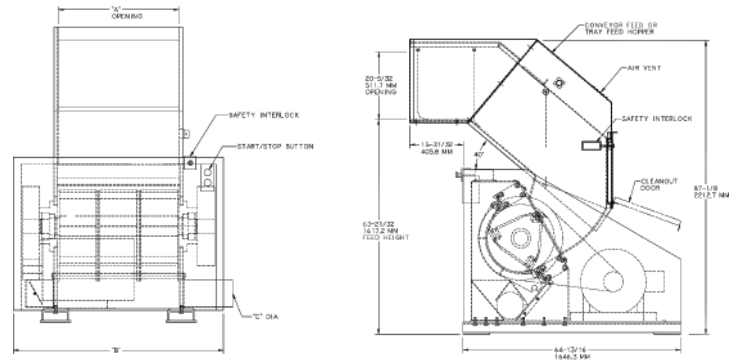

1100 E Woodfield Road
Schaumburg, IL 60173 USA
Tel. 847-273-7700 Fax 847-273-7804

www.[aceinternet.com](http://www.aceinternet.com)

