



AUTOMATE

APEX SA SERIES SINGLE AXIS TRAVERSING ROBOTS



STATE OF THE ART CONTROLLER

The one-key/one function controller comes with a large LCD screen, providing easy and user-friendly operation.

- 10 standard and 10 teachable programs
- Each teachable program can write up to 100 steps, with up to 4 motion sequences per step
- The Self Diagnostic System surveys input/output status at all times and can accumulate up to 20 error messages
- Traverse axis speed can be adjusted by percentage rate



STANDARD FEATURES

- Cable guide protection on electrical wires and hoses
- AC brushless servomotor drive on traverse axis is accurate to within +/- 0.1mm
- Uniquely designed wrist flip device with air shut off pin, excellent for protecting and changing your end-of-arm tooling
- Power Source: 120V - Single Phase Standard (220V optional)
- 1 pressure and 1 vacuum circuit
- Quick change end of arm tool system with basic end of arm tool vacuum pad and frame are standard
- Parts drop off can be accomplished with 9 programmable cycle positions and 2 areas for 18 points.
- 8 spare output and 5 spare input terminals for connection to conveyors, spray mist, shear cutters, and sensors
- Counter can be set to drop parts for inspection at regular intervals or to stop after a designated quantity has been reached
- I/O available to detect reject signals and drop reject parts at a designated point

OPTIONAL FEATURES

- Extend traverse stroke by 7.8" (200 mm)
- Additional vacuum circuit (total of 2)
- Additional pressure/grip circuit (circuit only, no gripper/nipper) (total of 2)
- Wrist rotate
- Additional end of arm tooling quick change system
- Telescopic vertical arm for overhead clearance issues
- Sub-arm configurations for 3-plate mold applications



c/o ACS Automation
2900 S 160th Street
New Berlin, WI 53151 USA
Tel. 262.641.3838 Fax 262.641.8651



WHITLOCK/
MATERIAL
HANDLING



HEAT & COOL



BLEND &
RECLAIM



NELMOR/
GRANULATE



DOWNSTREAM
EXTRUSION



AUTOMATE



SYSTEMS
CONTRACTING



SERVICE



AUTOMATE

APEX SA SERIES SINGLE AXIS TRAVERSING ROBOTS

SPECIFICATIONS

Model Number		Dry Cycle (sec.)		I.M.M. Range (tons)	Stroke (mm)					Max. Payload (kgs)		Net Weight (kgs)	Comp. Air Consumption (NL/Cycle)
		Take-Out	Cycle		Strip		Vertical	Traverse	main	sub			
					main	sub					main		
SA-700	Single-stage, single arm	1.2	11	80-200	150	--	700	--	1226	3	--	180	37
SA-700S	Single-stage, sub arm					100		750			3	190	42.5
SA-700T	Telescopic, single arm					--		--			--	200	32.5
SA-700TS	Telescopic, sub arm					100		750			3	210	41
SA-900	Single-stage, single arm	1.4	12	200-450	200	--	900	--	1406	3	--	185	46.5
SA-900S	Single-stage, sub arm					100		950			3	200	52.5
SA-900T	Telescopic, single arm					--		--			--	210	40.5
SA-900TS	Telescopic, sub arm					100		950			3	220	50.5
SA-1200	Single-stage, single arm	1.6	13	450-650	300	--	1200	--	1646	6	--	190	59.5
SA-1200T	Telescopic, single arm					--		--			--	215	51.5
SA-1200TS	Telescopic, sub arm					100		1250			3	230	63.5

	A	B	C	D	E	F	G	H	I	J	K
700	2100	1226	100	1000	1417	370	180	154.5	150	565	779
700S	2100	1226	100	1000	1417	370	180	154.5	150	380	779
700T	2100	1226	79	1000	1125	410	140	114.5	150	515	769
700TS	2100	1226	79	1000	1125	410	140	114.5	150	300	769
900	2280	1406	100	1120	1617	370	180	154.5	200	685	899
900S	2280	1406	100	1120	1617	370	180	154.5	200	500	899
900T	2280	1406	79	1120	1225	410	140	114.5	200	635	889
900TS	2280	1406	79	1120	1225	410	140	114.5	200	420	889
1200	2520	1646	100	1240	1917	393	157	127	300	805	1029
1200T	2520	1646	79	1240	1375	410	140	110	300	755	1013
1200TS	2520	1646	79	1240	1375	410	140	110	300	505	1013

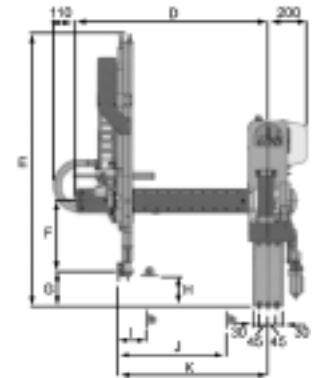
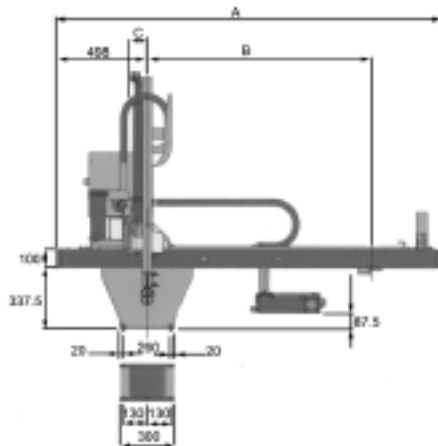

c/o ACS Automation
 2900 S 160th Street
 New Berlin, WI 53151 USA
 Tel. 262.641.3838 Fax 262.641.8651

ENGINEERING TOTAL PROCESS SOLUTIONS WITH INTEGRATED AEC EQUIPMENT

AEC is committed to a continuing program of product improvement.
 ©2007 AEC, Inc.

Bulletin AA2-125.3

Specifications, appearances and dimensions are subject to change without notice.
 Printed in USA