



NELMOR-GRANULATE

WG 1400 SERIES THERMOFORMING GRANULATORS



WG 1400 SERIES THERMOFORMING GRANULATORS

The AEC WG 1400 Series offer reclamation of thermoformed, extruded scrap, sheet, web and edge trim. With a standard 50 HP motor and throughput capacities up to 3,000 lbs/hr, there is a AEC granulator ideal for your specific needs. The WG 1400 Series models include 14x56 and 14x62. Both provide heavy-duty construction and quiet operation. Double sealed bearings are lubricated for life.

STANDARD FEATURES

- Open (wing) type design rotor
- Quick access to cutting chamber with swing down screen cradle for ease of service and cleaning
- Double sealed, outboard mounted heavy-duty spherical bearings prevent bearing contamination

ADDITIONAL STANDARD FEATURES

- 3 Chevron-positioned rotor knives scissor cut against the bed knives to provide optimum cutting efficiency with low power consumption
- Heavy-duty construction allows noise reduction of 85 dBA or less for most applications
- Reinforced, heavy-duty screen cradle
- Optimum cutting efficiency with Twinshear™ knife configuration

OPTIONS

Motor:

- 40-100 HP REFC motors
- Special voltage (e.g. 208, 380, 415, 575)
- Magnetic disc brake

Infeed:

- Dual feed hopper, pneumatic lift assembly, feed rolls, paddle rolls
- Sheet feed hopper

Discharge:

- 8" or 10" airveyor chute

Knives:

- HCHC with TCSC

Base:

- Drum/gaylord, angular, leg type
- Raised base



1100 E Woodfield Road
Schaumburg, IL 60173 USA
Tel. 847-273-7700 Fax 847-273-7804

www.aecinternet.com



**WHITLOCK/
MATERIAL
HANDLING**



HEAT & COOL



**BLEND &
RECLAIM**



**NELMOR/
GRANULATE**



**DOWNSTREAM
EXTRUSION**



AUTOMATE



**SYSTEMS
CONTRACTING**



SERVICE



NELMOR-GRANULATE

WG 1400 SERIES THERMOFORMING GRANULATORS

Specifications		
Model	14x56	14x62
Cutting Circle	14" (360 mm)	
Throughput	2200 lbs./hr (1000 kg)	3000 lbs./hr (5227 kg)
Cutting Chamber	2-bed knife, Twinshear	
Rotor Knives	HCHC, 55, Chevron	
Discharge	8" (14x56) and 10" (14x62) airveyor chute	
Motor	50 HP, 1200 RPM, TEFC, 3/60/230/460	
Drive Parts	V-belt	
Base	Low profile airveyor	
Electrical Components	NEMA 12 with safety interlocks	
Controls	Customer supplied	
Chamber Size	14" x 56" (356 x 1422 mm)	14" x 62" (356 x 1568 mm)
Feed Height	64" (1625 mm)	122" (3099 mm)
Overall Length	62 1/2" (1587 mm)	102" (2591 mm)
Overall Width	117 5/8" (2988 mm)	90" (2286 mm)
Weight	11,500 lbs. (5227 kg)	17,000 lbs. (7727 kg)

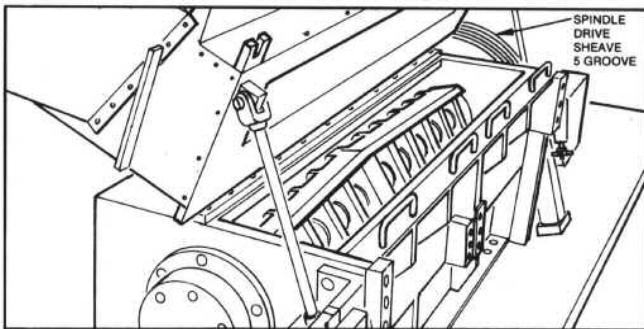
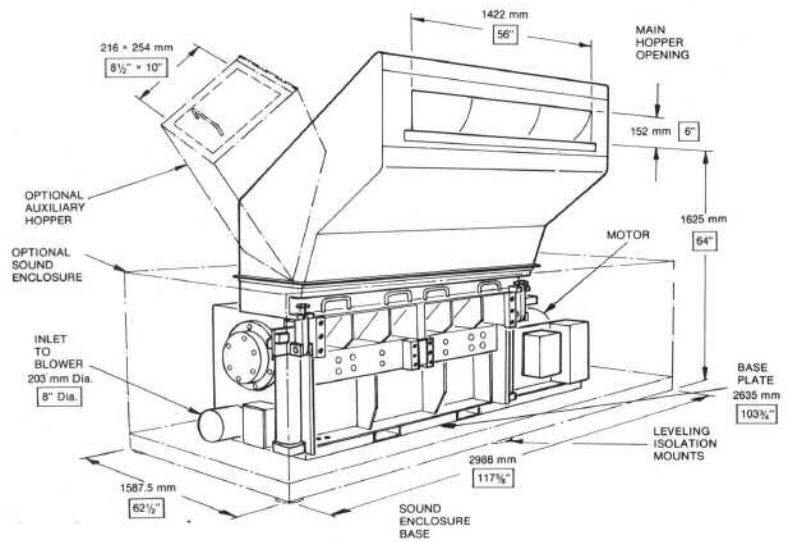

1100 E Woodfield Road
Schaumburg, IL 60173 USA
Tel. 847-273-7700 Fax 847-273-7804

www.aecinternet.com

